

LUMBER WALL SEATING

ASSEMBLY INSTRUCTION

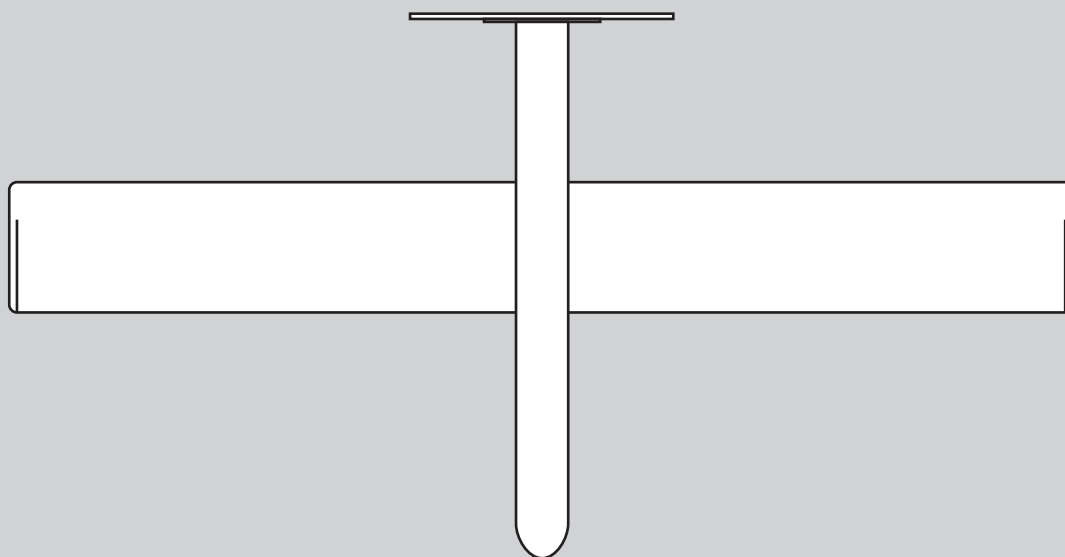

PARTS

Wall mounted Lumber includes .

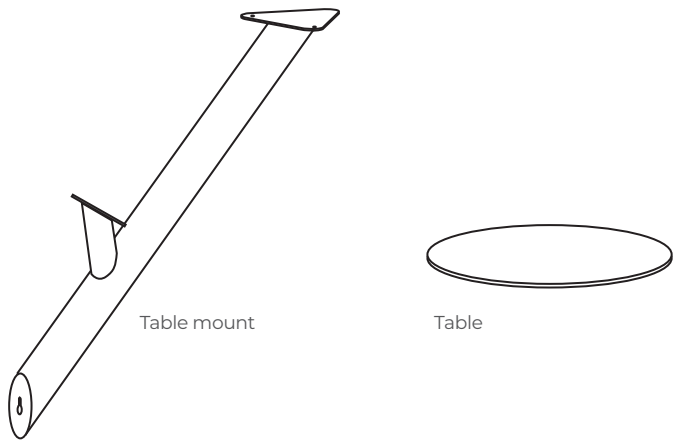
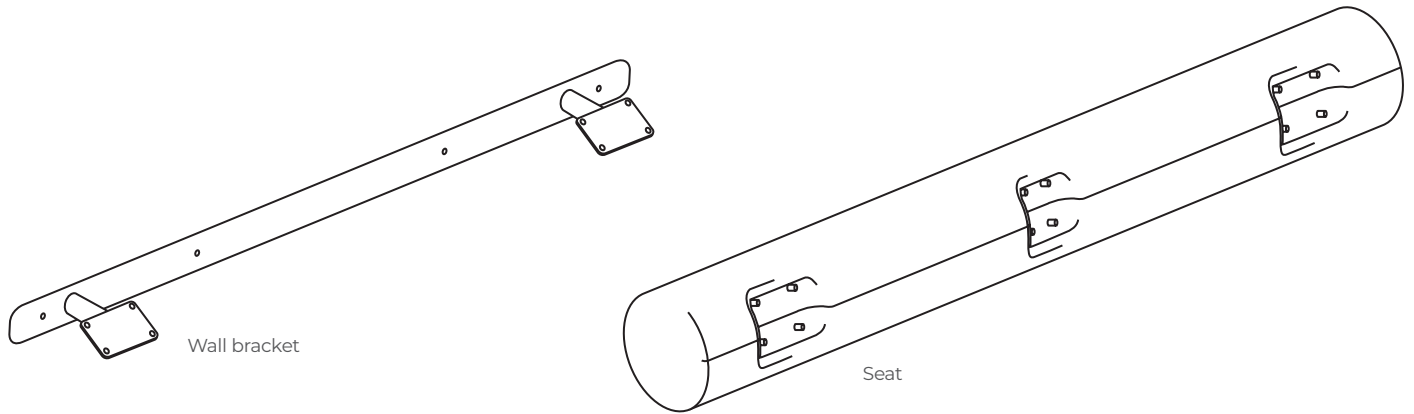

Nut M8
x12pcs

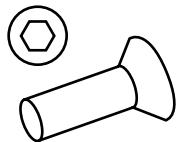

Hex bolt
x3pcs



Washers
x12pcs

TOOLS

To assamble and mount Lumber Wall you need following tools.

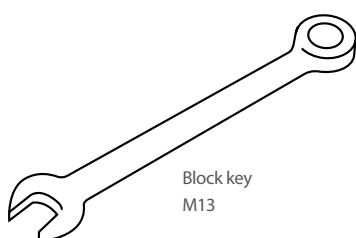

Block key
M13

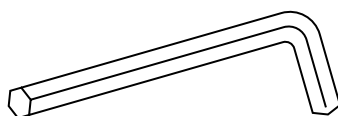

Hex key

ASSEMBLE LUMBER WALL

The construction is easy to assemble with few parts.

1. PREPARE THE WALL

Start by measure out the right distance for the screws. 600mm up from the floor and then 1260mm in width total (350mm between the outer holes).

There should also be a hole in the middle, 265mm up for the table leg.

 Make sure your wall is strong enough for a lumber wall and for advice on suitable screws and plugs, contact your specialized dealer.

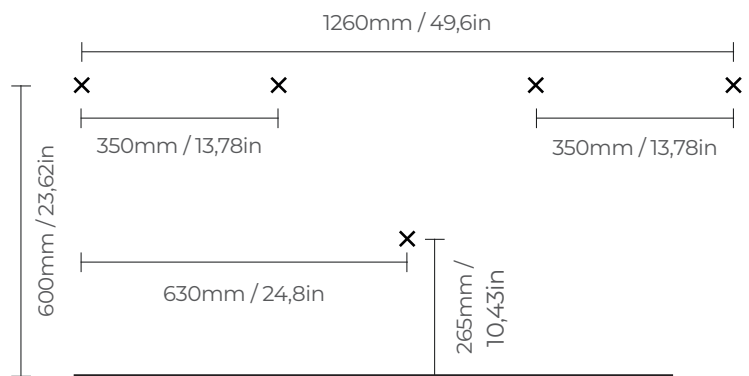

On the packaging of Lumber there is also a printed 1:1 stencil with the correct hole pattern for the wall bracket to make it easier to measure out where to drill.

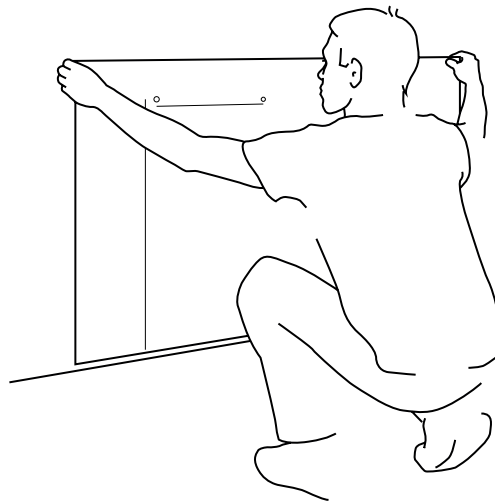

2. FIX THE WALL BRACKET

When the wall is prepped, mount the wall bracket.

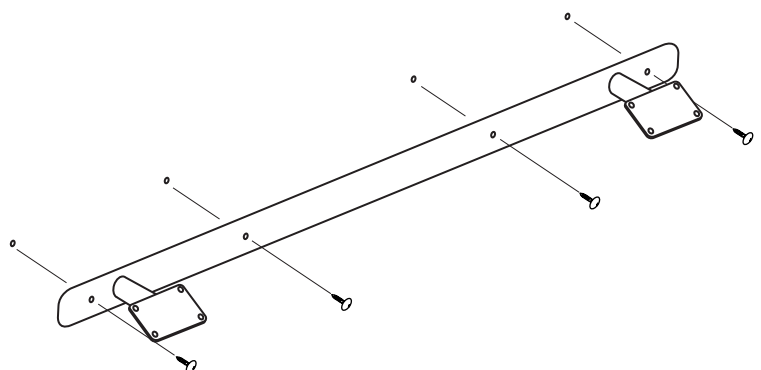

3. ATTACH THE TABLE MOUNT

When the wall is prepped, attached the wall mount on the seat.

Don't forget to **put on the washers before you attach the table mount.**

Use the block key.

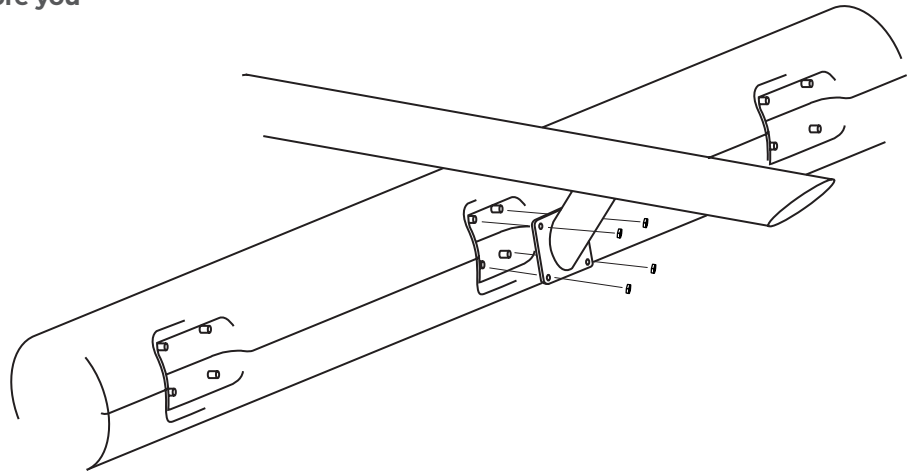
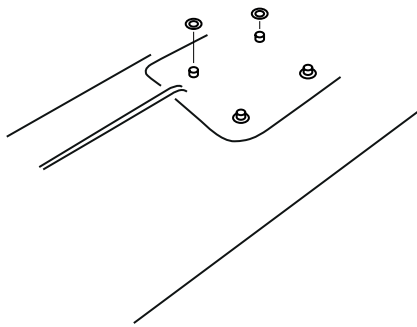

4. MOUNT THE SEAT

Now it's time to mount the seat on the wall bracket.

Take help and carefully lift the seat in place making sure that the seat is fixed on the wall bracket and on the screw for the table mount.

Don't forget to **put on the washers before you mount the seat on the bracket.**

Use the block key.

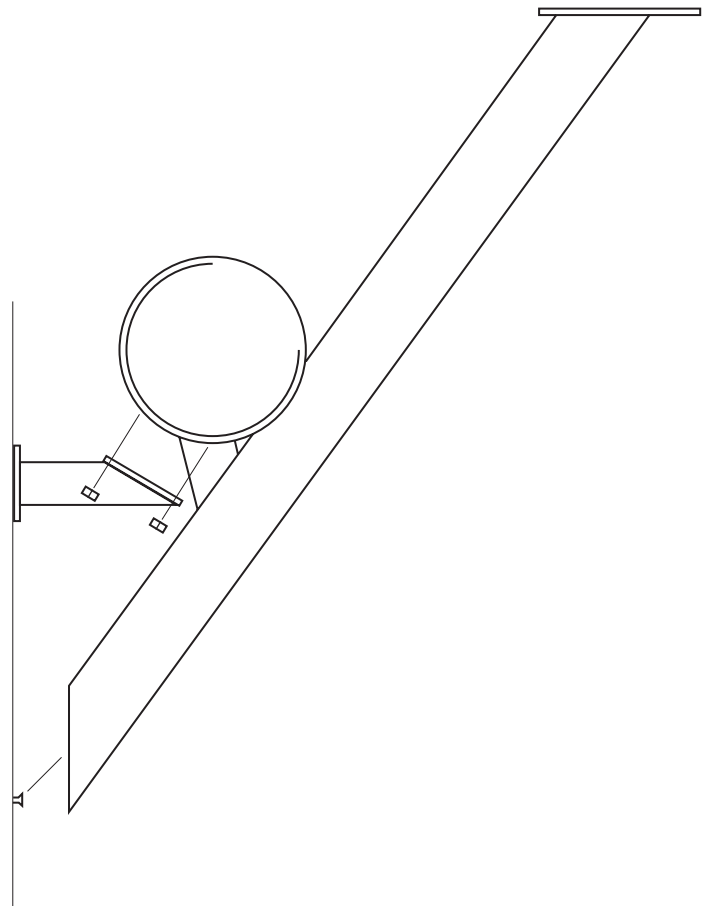
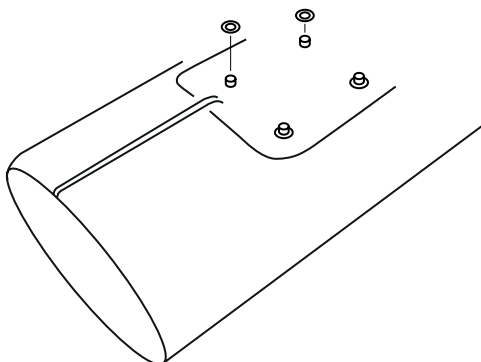

5. MOUNT THE TABLE

When the seat is in place and fixed you can attach the table on the table mount.

Use the hex key.

 Note that the table is not suitable for sitting. Recommended max weight is 10kg.

